

Innovative FLEXOMANT MODULES for weed control with proven ULV technology!

**NEW
2016!**



→ Wheel-driven pump for path dependent minimal dosage of herbicides

→ Parallelogram for constant distance between ground and spray hood(s)

→ Innovative Flex spray hoods and many other features



Components of a Flexomant module

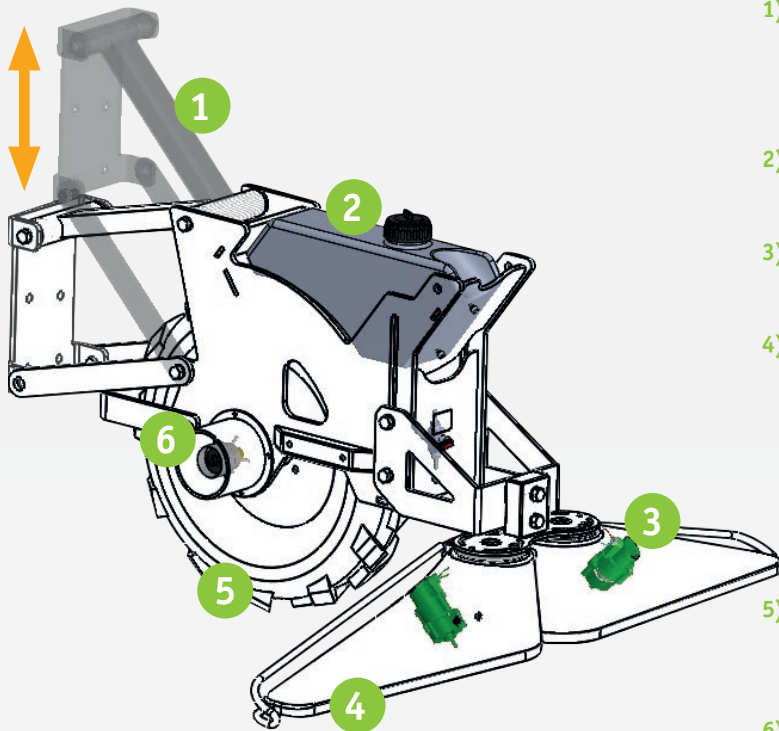

- 1) A parallelogram suspension system is used to connect the Flexomant module to an equipment rack of choice as well as to ensure a permanent contact of the wheel to the ground and a constant distance between ground and spray hoods.
- 2) The 3-litre tank can cover a surface of up to 3 ha depending on which herbicide is being used.
- 3) The segment rotation atomiser sprays undiluted herbicide vertically downwards, thus minimising the risk of drift.
- 4) One or two Flex spray hood(s), each with one segment rotation atomiser, cover a maximum spray width of 25 to 110 cm. The height of the spray hood(s) to the ground is adjustable. The spray hoods fold back upon contact with an obstacle so that the spray width is automatically adjusted, e.g. in case of irregular distance between rows. The maximum spray width can be reduced whilst keeping the Flex-mechanism, or, if the Flex-mechanism is not wanted, the spray width can be fixed.
- 5) A robust wheel with solid tyre profile reduces slipping on challenging surfaces like loamy soil, thus ensuring path dependent metering even under difficult conditions.
- 6) A wheel-driven pump ensures path dependent, exact herbicide dosage on the treated area.

Depending on the area of application one or more Flexomant modules can be fixed on an equipment rack of choice for mounting to a range of vehicles.

Mounting examples



- 1) Direct mounting of a Flexomant module to a 3-point-hitch for full surface coverage with a spray width of 110 cm, e.g. on paths or in cultivations with narrow rows.



- 2) Set of two Flexomant modules, each with one spray hood and on an extension arm for side spraying in row cultivations like orchards.



- 3) Set of three Flexomant modules on an equipment rack for full surface coverage of up to 330 cm spray width, e.g. on large lawns in parks or golf courses.

Do you have any questions? We are pleased to advise you!

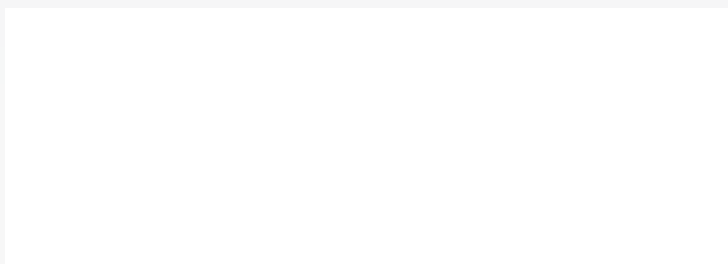

MANTIS ULV®
SPRAYING SYSTEMS

Mantis ULV-Sprühgeräte GmbH

Vierlander Straße 11a

21502 Geesthacht, Germany

Phone: +49 (0)4152 / 8459-0

Fax: +49 (0)4152 / 8459-11

mantis@mantis-ulv.eu · www.mantis-ulv.eu