

OPERATING INSTRUCTIONS

FLEXOMANT 1W -2W -3W -4W ^{CE}

FLEXOMANT 4W PLUS

**ULV- Applicator for weed control
in areas of specialised cultivation such as nurseries, orchards and
vineyards, ornamental plant and vegetable gardens, as well as
agricultural, forestry, communal and non-cultivated lands.**

**The unit has been developed for the *undiluted*
application of ROUNDUP® products (Glyphosate).**

Important:

Before application, carefully read the usage instructions for the unit and the plant protective agent!
Observe safety instructions!

For questions regarding plant protective agents, consult the manufacturer!

Observe the requirements and regional regulations for the use of herbicides and, if necessary,
obtain approval from the responsible authorities (e.g. environmental conservation agency)!

Application is to be performed only by a competent user.

Remarks about usage of the unit:

Settings: This system is not suitable for the application of water.
Use herbicides for testing the spray action and calibration of the
flow rate.



Keep the applicator and pesticides out of the reach of children.

Noise emission from the unit equates to less than 70 dB(A).

Manufacturer:

Mantis ULV-Sprühgeräte GmbH

D-21502 Geesthacht, Vierlander Str. 11 a

Telephone + 49 (0)4152 / 8459-0, FAX + 49 (0)4152 / 8459-11

FLEXOMANT

For the undiluted application of Roundup® products (Glyphosate)

The instructions on this page are valid for all VARIMANT applicator units. Details regarding assembly, use and replacement parts are provided on the following pages:

FLEXOMANT-1W,	FLEXOMANT-2W:	Pages 4
FLEXOMANT-3W:		Pages 5
FLEXOMANT-4W:		Pages 6
FLEXOMANT-4W Plus:		Pages 7

Intended usage:

Weed control in areas of specialised cultivation such as nurseries, orchards and vineyards, ornamental plant and vegetable gardens, as well as agricultural, forestry, communal and non-cultivated lands.

Before application, carefully read the usage instructions for the applicator unit and pesticides.

Observe safety instructions.

For questions regarding pesticides, consult the manufacturer!

Observe the requirements and regional regulations for the use of herbicides. Permission is required from the responsible authorities (e.g. environmental conservation agency) for the application of herbicides on surfaces used for non-agricultural, forestry or gardening purposes ("non-cultivated lands"). Application is not permitted on sealed surfaces (e.g. pavement surfaces) with connection to sewage water systems from which the danger of run-off exists! Application is to be carried out only by a competent user.

Noise emission from the unit equates to less than 70 dB (A).

Protective measures

Observe the remarks in the pesticide usage instructions regarding user safety and wear recommended body protection. Wear protective gloves when filling the chemical substance.

Do not eat, smoke or drink while working with pesticides. Avoid chemical spillage without fail. Thoroughly clean hands and face after completion of work.

Thoroughly clean and dry the unit immediately following its usage. Never use the mouth to blow out nozzles or other small parts!



Keep pesticide applicators and chemical substances away from children.

Assembly and preparation for initial application

Unit assembly is described for the individual models. Assembly of the spray hoods according to the draft on page 5. and connect all plugs. Please connect the hoses not until the output volume is checked. To check the spray width place underlay (cardboard or paper) on the ground and select a output quantity.

General remarks regarding applicator unit function and deployment

Pesticides: This applicator unit was originally designed for the undiluted application of Roundup products (Glyphosate). Practical experience has shown, however, that other herbicides can also be deployed in conjunction with this technology. Considering the many products on the market with their differing formulations, it is not possible to provide a complete list with application rate recommendations. Specifications for adjusting the unit listed on following pages relate to the usage of Roundup UltraMax (Glyphosate 450 gr/ltr). In general, all products with a comparable viscosity are suitable. If it is intended to use a product other than Roundup UltraMax, its application should be first tested over a small area on a trial basis. Usage instructions for the chosen herbicide should be observed in every case, along with local requirements.

Applicator unit function: Rotating atomisers are driven by means of a rechargeable battery. Metering on all the units mentioned is path-dependent and takes place by means of a wheel driven pump. Droplets are formed by the centrifugal force of the rotating atomiser. The droplets are discharged downwards by the rotating atomiser through a continuously variable, adjustable segment. Residual chemical in the tank not intended for application is approx. 50 ml. This residual fluid can be refilled back into the original herbicide container.

Checking applicator unit function: Chemical solutions may flow quicker or slower due to temperature fluctuations, for which reason the flow rates in the Metering table should be checked and corrected as necessary. This system is not suitable for the application of water. Please use herbicides at all times for testing the spray process and calibrating the flow rate. Check the rotating atomiser on a daily basis for cleanliness and free turning motion. Check the output volume from time to time throughout the season.

Deployment of the applicator unit: Adjust the height of the spray hood in such a manner that it is as close to the ground as possible - if it is set too high, the risk of spray driftage exists. During operation, chemical fluid will collect in the rotating atomiser reservoir and will continue to drip for approx. 30 seconds after the shut-off valve has been closed if the unit is tilted. In order to avoid damage to cultivated plants due to dripping, we recommend closing the shut-off valve at the end of a row, for example, then folding the spray hood upwards and waiting approx. 30 seconds until the reservoir has emptied.

Spray width

- Place an underlay (cardboard or paper) on the ground and prop up the unit on stands.
- Actuate the switch button on the powerpack while simultaneously turning the wheel and appraising the spray width obtained, initially at one location. The spray width must be set in such a manner that the droplets are discharged over the entire width of the spray hood. The optimal spray width under standard operating conditions is set by the manufacturer.
- Compensate for deviations is possible by loosening screw (F) and sliding the width adjustment on the atomiser (see drawing).
- Further details regarding operating width adjustment can be found on the respective pages for the individual applicator units.

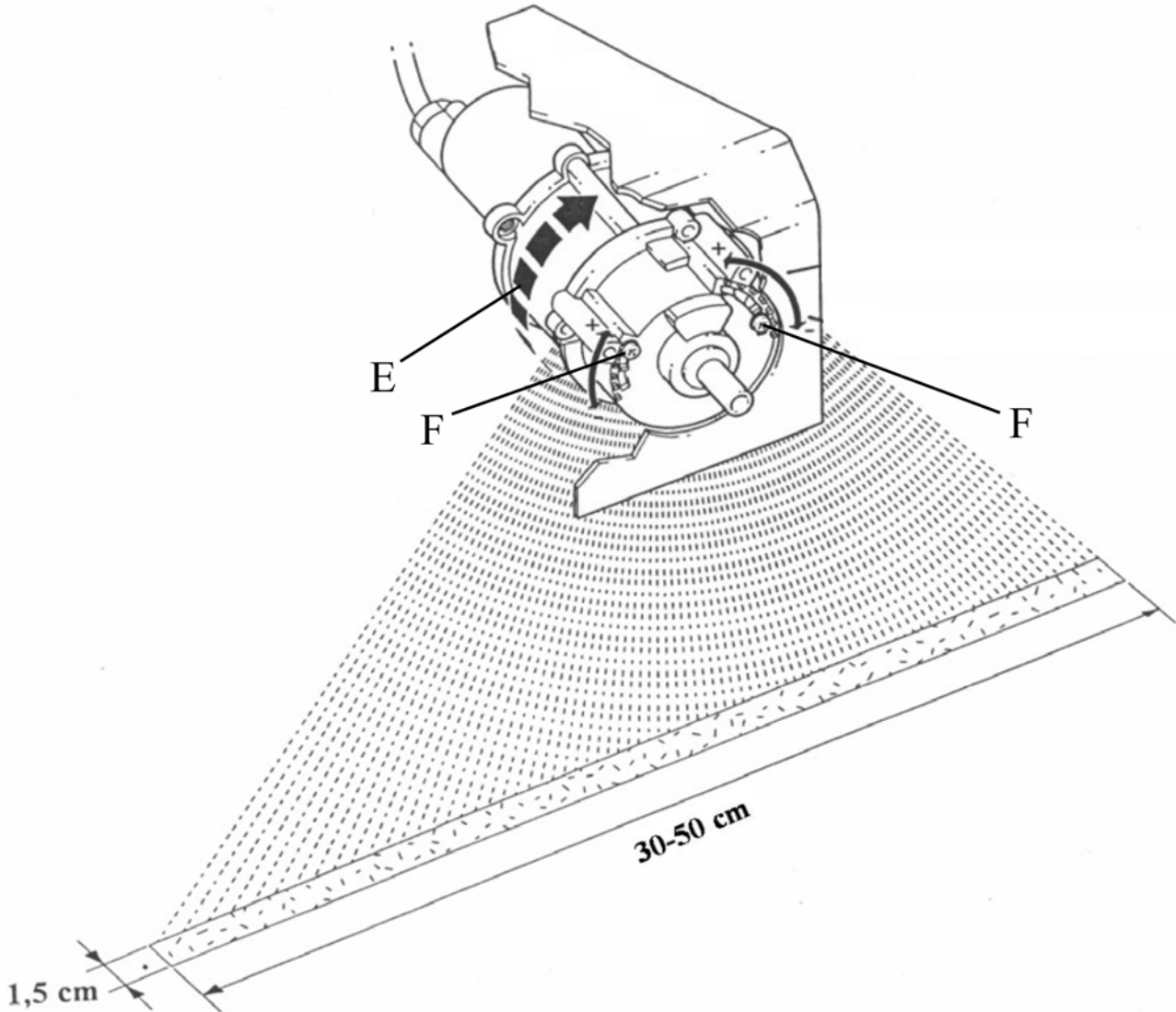

Cleaning

Do not clean the applicator unit with a high-pressure sprayer or with an intense water jet spray.

Cleaning during the season: During short work breaks (a few hours), herbicide can remain in the system as long as the shut-off valve remains closed. After work completion: before cleaning, refill the chemical solution into its original container. Open the shut-off and set the metering pump to maximum. Fill the chemical tank halfway with water, then, with the unit positioned, turn the wheel smoothly 50 x and allow the fluid to drain into a collector tank or, operating the unit for approx. 100 m, apply the cleaning fluid to the already treated surface. Remove any remaining water from the tank and turn the wheel 50 x once again until the system is completely empty.



Cleaning at the end of the season: Rinse the unit with warm water as described above. Additionally: Unscrew filter and clean screen as necessary. The spray hood and the atomiser housing can be cleaned with a moist cloth. Remove the atomiser disc in order to avoid damage. With heavy contamination, the atomiser housing should be unscrewed to remove contaminants and plant parts. Connect the unit to the charging device (see below).

FLEXOMANT-1W und FLEXOMANT-2W

Ball valve closed

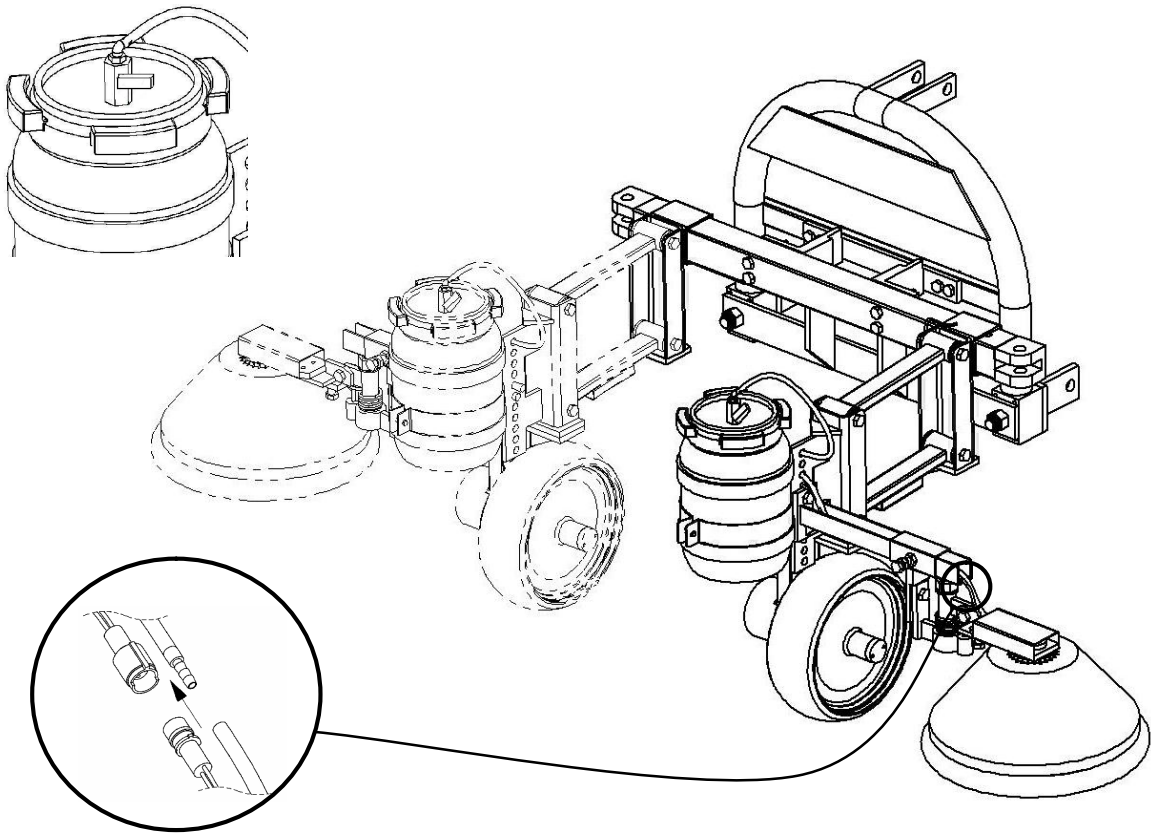

Assembly

1. Mount the spraying system on the vehicle.
2. Connect electrical plug 12 V-with the socket of the vehicle. Please check the vehicle polarity. If the plug is removed , blue lead is (+), brown lead (-).
3. Set ground clearance of the spray hood.
4. Connect control box with pump unit .
5. Check spray width of the atomiser.
(see drawing page 3)
6. After checking the output volume (workflow on the right) connect all hoses.

Metering table

Roundup UltraMax application rate at 20°C

Roundup UltraMax	Dosierknopf Stellung	Benötigte Ausbringmenge in ml pro Düse bei 50 Radumdrehungen
1,0 l/ha	A	ca. 1,9
2,0 l/ha	C	ca. 3,8
3,0 l/ha	F	ca. 5,60

Checking the output volume

1. Place an underlay (e.g. cardboard or paper) on the ground and prop up the unit on stands.
2. Fill the chemical tank with herbicide - undiluted.
3. Remove the hose from the lower side of the flow rate control and place a measuring cup underneath.
4. Open the shut-off valve, initially setting the metering adjustment knob to the maximum flow rate and simultaneously turning the wheel; wait until the chemical solution is evenly applied.
5. Set the chemical solution volume according to the output table.
6. Volume calibration: Collect the chemical solution from 50 wheel revolutions into a measuring cup. If the desired volume is not reached, set a larger or a smaller volume with the pump metering adjustment knob.
7. Perform volume calibration again.
8. Reconnect the hose on the lower side of the flow rate control.
9. The unit is now ready for deployment.

FLEXOMANT-3W

Ball valve closed

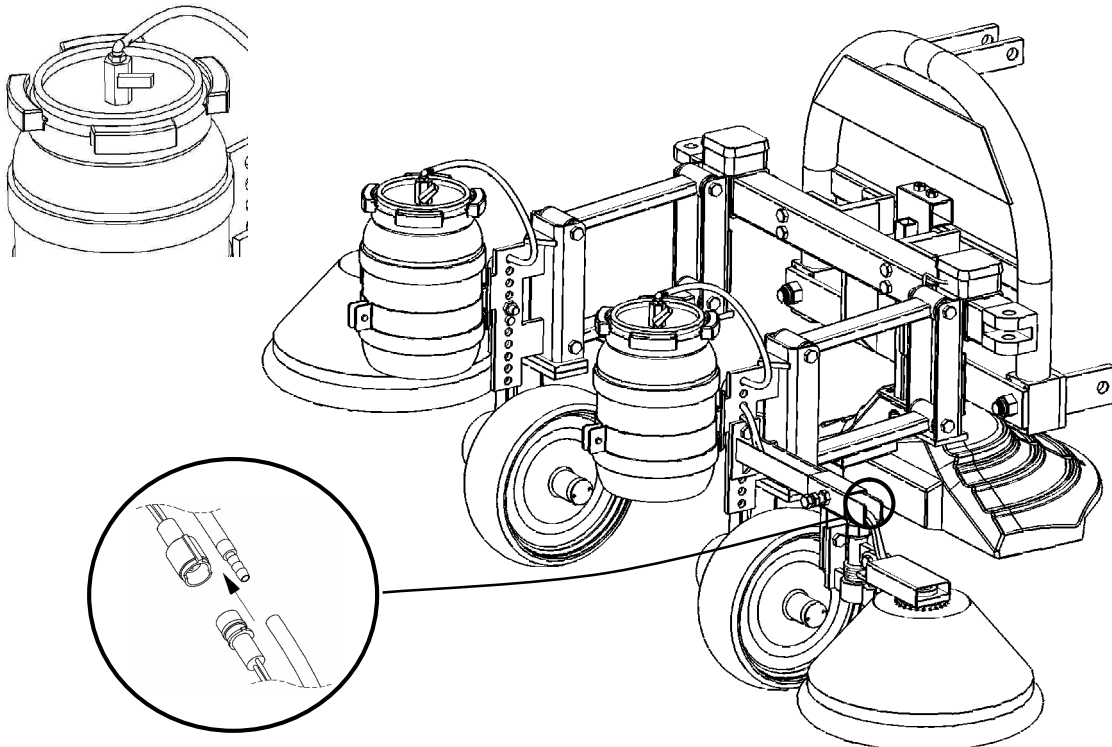

Assembly

1. Mount the spraying system on the vehicle.
2. Connect electrical plug 12 V-with the socket of the vehicle. Please check the vehicle polarity. If the plug is removed, blue lead is (+), brown lead (-).
3. Set ground clearance of the spray hood.
4. Connect control box with pump unit.
5. Check spray width of the atomiser. (see drawing page 3)
6. After checking the output volume (workflow on the right) connect all hoses.

Metering table

Roundup UltraMax application rate at 20°C

On the wheel in driving direction right is a MAFEX pump mounted which feeds the spray hood in the middle.

Roundup UltraMax	Dosierknopf Stellung	Benötigte Ausbringmenge in ml pro Düse bei 50 Radumdrehungen
1,0 l/ha	A	ca. 2,4
2,0 l/ha	C	ca. 4,7
3,0 l/ha	E	ca. 7,1

On the wheel in driving direction left is a MANKAR pump mounted which feeds the outer spray hoods

Roundup UltraMax	Dosierknopf Stellung	Benötigte Ausbringmenge in ml pro Düse bei 50 Radumdrehungen
1,0 l/ha	A	ca. 1,9
2,0 l/ha	C	ca. 3,8
3,0 l/ha	F	ca. 5,60

Checking the output volume

1. Place an underlay (e.g. cardboard or paper) on the ground and prop up the unit on stands.
2. Fill the chemical tank with herbicide - undiluted.
3. Remove the hose from the lower side of the flow rate control and place a measuring cup underneath.
4. Open the shut-off valve, initially setting the metering adjustment knob to the maximum flow rate and simultaneously turning the wheel; wait until the chemical solution is evenly applied.
5. Set the chemical solution volume according to the output table.
6. Volume calibration: Collect the chemical solution from 50 wheel revolutions into a measuring cup. If the desired volume is not reached, set a larger or a smaller volume with the pump metering adjustment knob.
7. Perform volume calibration again.
8. Reconnect the hose on the lower side of the flow rate control.
9. The unit is now ready for deployment.

FLEXOMANT-4W

Ball valve closed

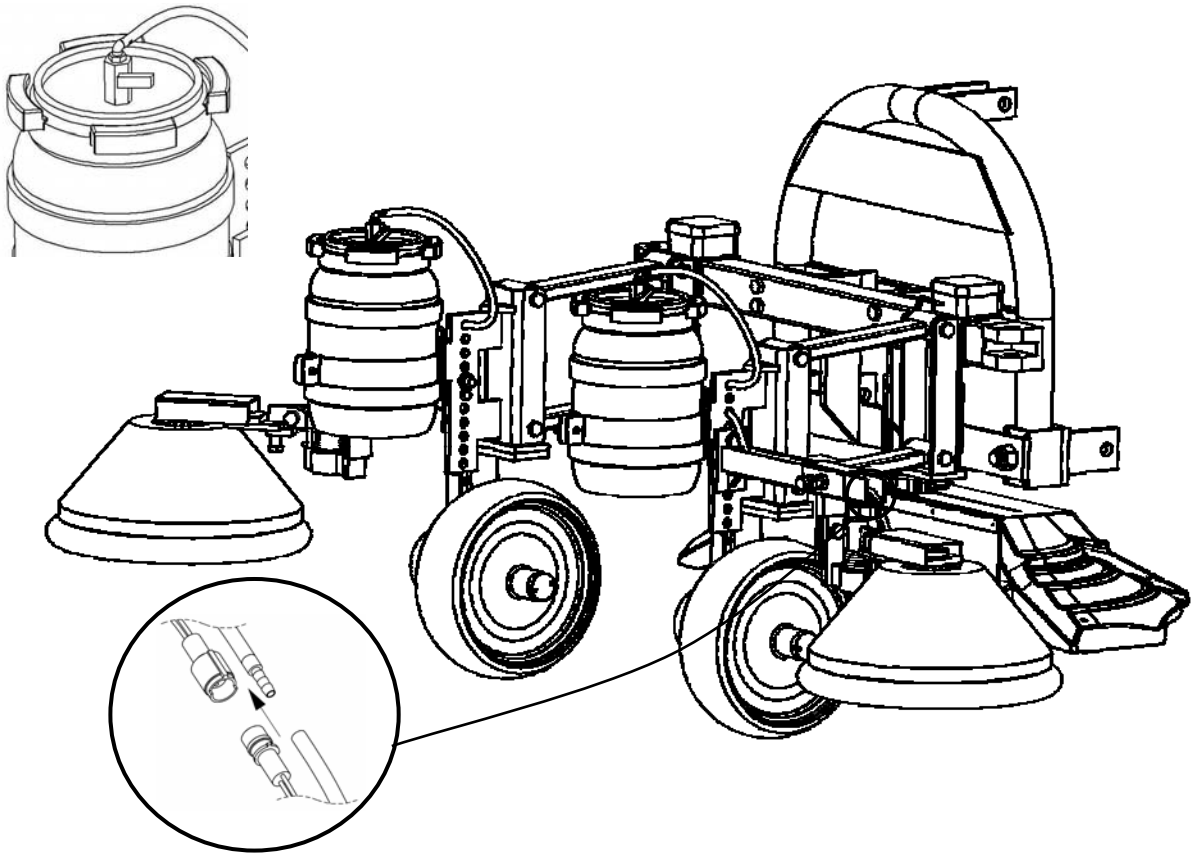

Assembly

1. Mount the spraying system on the vehicle.
2. Connect electrical plug 12 V-with the socket of the vehicle. Please check the vehicle polarity. If the plug is removed , blue lead is (+), brown lead (-).
3. Set ground clearance of the spray hood.
4. Connect control box with pump unit .
5. Check spray width of the atomiser.
(see drawing page 3)
6. After checking the output volume (workflow on the right) connect all hoses.

Metering table

Roundup UltraMax application rate at 20°C

On both wheels MANKAR pumps are mounted they feed the atomizers depending on the chosen variant. One option is to feed both atomizer on the left side with one pump to realise a left/right disconnection. Another option would be the breakdown in outer and internal spray hoods

Roundup UltraMax	Dosierknopf Stellung	Benötigte Ausbringmenge in ml pro Düse bei 50 Radumdrehungen
1,0 l/ha	A	ca. 1,9
2,0 l/ha	C	ca. 3,8
3,0 l/ha	F	ca. 5,60

Checking the output volume

1. Place an underlay (e.g. cardboard or paper) on the ground and prop up the unit on stands.
2. Fill the chemical tank with herbicide - undiluted.
3. Remove the hose from the lower side of the flow rate control and place a measuring cup underneath.
4. Open the shut-off valve, initially setting the metering adjustment knob to the maximum flow rate and simultaneously turning the wheel; wait until the chemical solution is evenly applied.
5. Set the chemical solution volume according to the output table.
6. Volume calibration: Collect the chemical solution from 50 wheel revolutions into a measuring cup. If the desired volume is not reached, set a larger or a smaller volume with the pump metering adjustment knob.
7. Perform volume calibration again.
8. Reconnect the hose on the lower side of the flow rate control.
9. The unit is now ready for deployment.

FLEXOMANT-4W PLUS

Ball valve closed

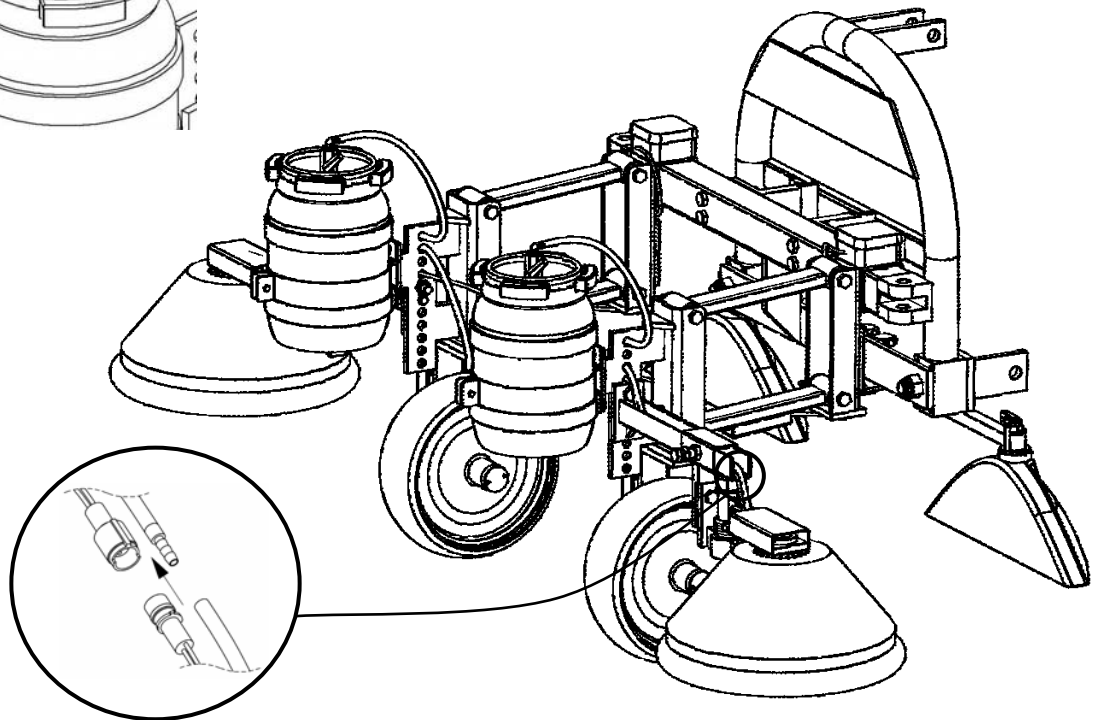
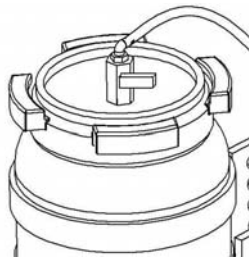

Assembly

1. Mount the spraying system on the vehicle.
2. Connect electrical plug 12 V-with the socket of the vehicle. Please check the vehicle polarity. If the plug is removed , blue lead is (+), brown lead (-).
3. Set ground clearance of the spray hood.
4. Connect control box with pump unit .
5. Check spray width of the atomiser.
(see drawing page 3)
6. After checking the output volume (workflow on the right) connect all hoses.

Metering table

Roundup UltraMax application rate at 20°C

On both wheels MANKAR pumps are mounted they feed the atomizers depending on the chosen variant. One option is to feed both atomizer on the left side with one pump to realise a left/right disconnection. Another option would be the breakdown in outer and internal spray hoods

Roundup UltraMax	Dosierknopf Stellung	Benötigte Ausbringmenge in ml pro Düse bei 50 Radumdrehungen
1,0 l/ha	A	ca. 1,9
2,0 l/ha	C	ca. 3,8
3,0 l/ha	F	ca. 5,60

Checking the output volume

1. Place an underlay (e.g. cardboard or paper) on the ground and prop up the unit on stands.
2. Fill the chemical tank with herbicide - undiluted.
3. Remove the hose from the lower side of the flow rate control and place a measuring cup underneath.
4. Open the shut-off valve, initially setting the metering adjustment knob to the maximum flow rate and simultaneously turning the wheel; wait until the chemical solution is evenly applied.
5. Set the chemical solution volume according to the output table.
6. Volume calibration: Collect the chemical solution from 50 wheel revolutions into a measuring cup. If the desired volume is not reached, set a larger or a smaller volume with the pump metering adjustment knob.
7. Perform volume calibration again.
8. Reconnect the hose on the lower side of the flow rate control.
9. The unit is now ready for deployment.

FLEXOMANT

1W
2W

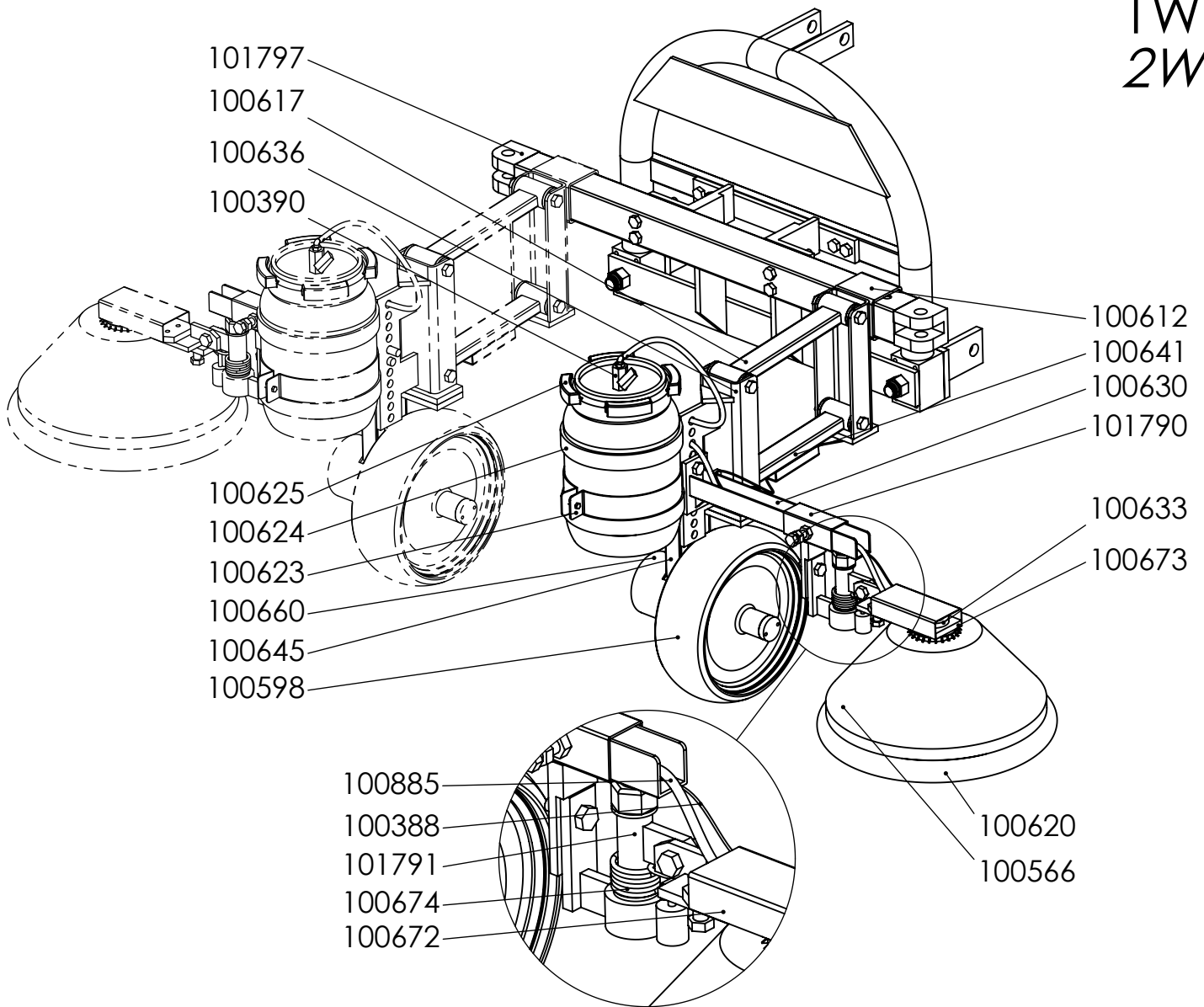

+ Flexomant 3W

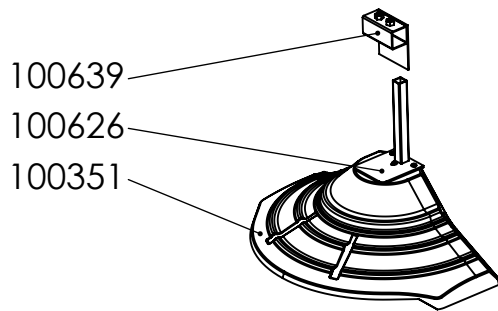

+ Flexomant 4W

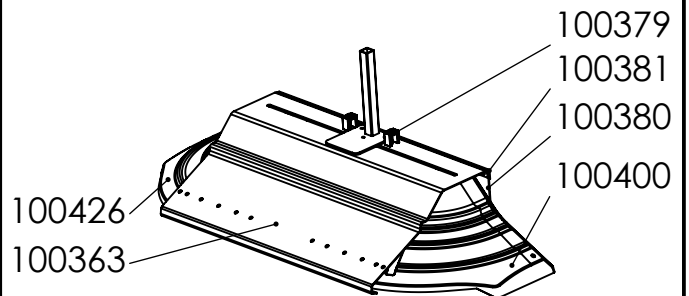

+ Flexomant 4W-Plus

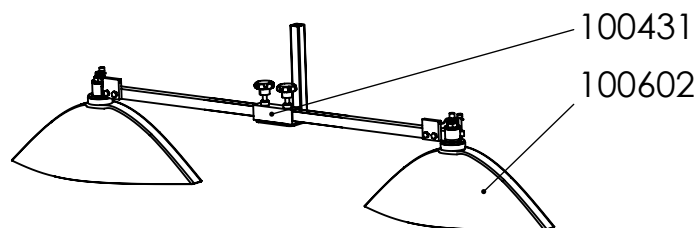

FLEXOMANT

Item Part No. Description

1	101797	3-point hitch for FLEXOMANT-VARIMANT
2	100617	Parallelogram for FLEXOMANT and TRAMA, TRAMUS
3	100636	Height adjustment, Flexomant
4	100390	Ball valve
5	100612	Suspension
6	100641	Parallelogram with cable protection
7	100630	Extension U-profile
8	101790	Width adjustment, right for VARIMANT/FLEXOMANT
9	100633	Ball bearing 6206 ZZ
10	100673	swinging arm FLEXOMANT/VARIMANT
11	100625	Tank lid for 6L tank
12	100624	Tank, capacity 6 litre
13	100623	Tank bracket for 6 litre tank
14	100660	Pump protection
15	100645	Pump support complete
16	100598	Farmflex wheel 300 x 100 mm
17	100885	Tube PVC, 4 x 2 mm, sold by metre
18	100388	Cable for atomiser
19	101791	Swivel-joint for FLEXOMANT-VARIMANT
20	100674	Spring 4mm for pivot FLEXOMANT/VARIMANT
21	100672	Covering sheet
22	100620	Casing 40 cm diameter
23	100566	Spray hood, conical, 36 cm diameter, plastic
24	100639	Bracket for height adjustmen
25	100626	Height adjustment for spray hood
26	100351	Spray hood, 50 cm
27	100379	Pull relieve
28	100381	Fastener for rubber curtain
29	100380	Rubber curtain for MANKAR-110 P + GP
30	100400	Spray hood, splitted 25 cm, left
31	100426	Spray hood, splitted 25 cm, right
32	100363	Metal hood, 600 mm width
33	100431	Bracket for MANKAR-L
34	100602	spray hood 45cm for FLEXOMANT-VARIMANT-4 Plus

Theoretical Spraying Width at various Sprayhood Heights

The height of the sprayhood has to be adjusted according to the height of the weeds.

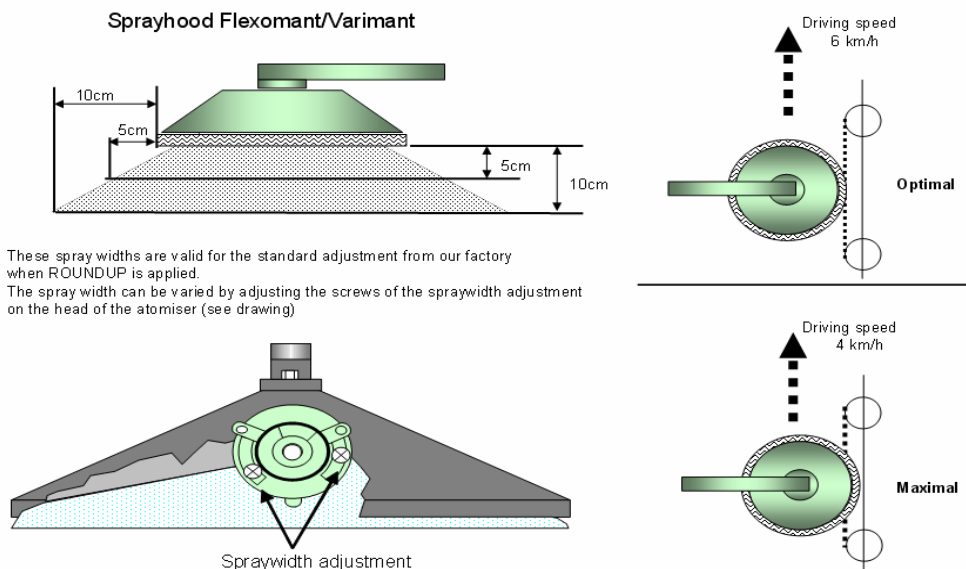

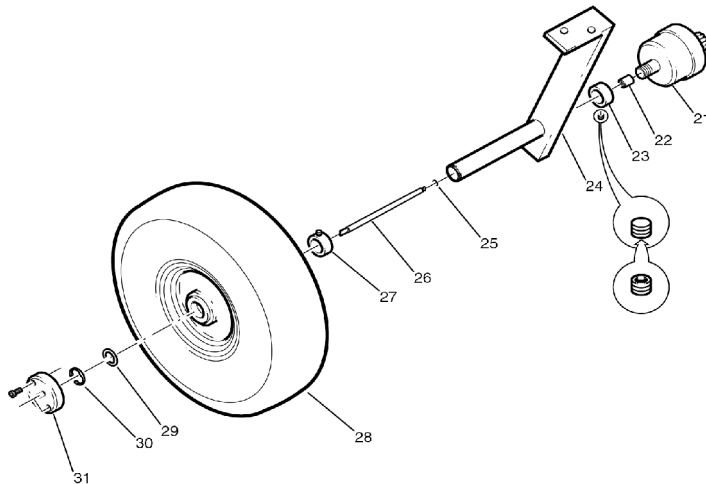

Item Part No. Description

100686 Pump drive subassembly FLEXOMANT

21	100522	Metering pump Mankar
22	100392	Screw socket
23	100389	Socket for pump
24	100645	Pump support complete
25	100141	O-ring 4,47 x 1,78 mm
26	100597	Cardan shaft-V
27	100377	Set collar 20 mm
28	100598	Farmflex wheel 300 x 100 mm
29	101832	Washer 28 x 1 mm
30	100394	Seeger circlip ring
31	100600	Cardan shaft driver

Dosierpumpe MANKAR

Dosierpumpe

Druckseite
Pressure sleeve
Pression

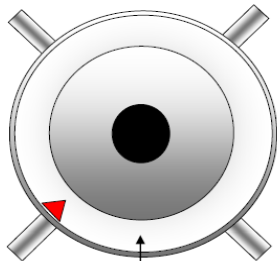

Saugseite
Sucking sleeve
Aspiration

Druckseite
Pressure sleeve
Pression

DOSIERKNOPF
Metering adjustment knob
Réglage de débit

Saugseite
Sucking sleeve
Aspiration

Druckseite / Pressure sleeve / Pression

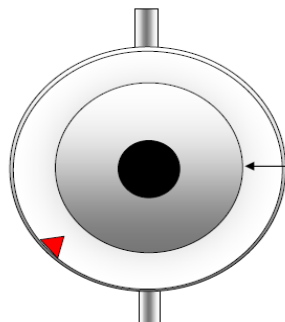

DOSIERKNOPF
METERING
ADJUSTMENT KNOB
RÉGLAGE DE DÉBIT

Saugseite
Sucking sleeve
Aspiration

What to do if the pump doesn't suck?

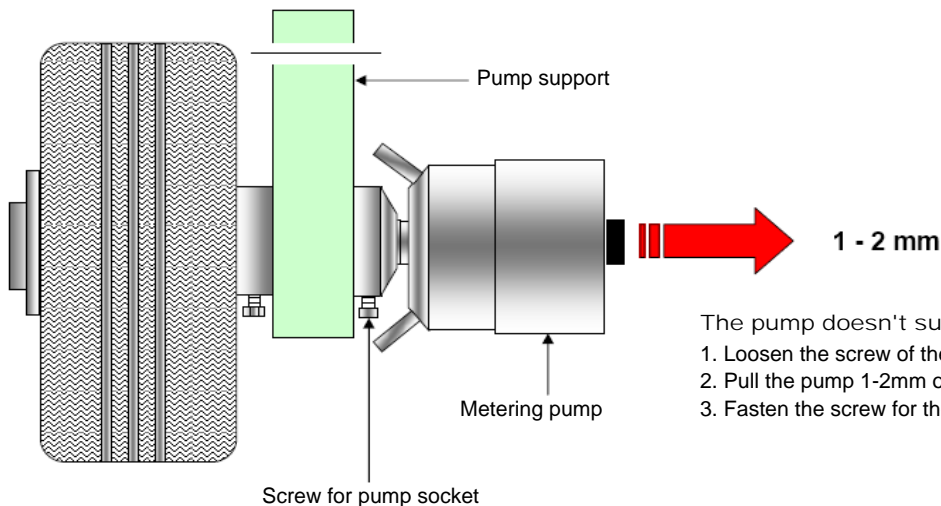

- The pump doesn't suck:
1. Loosen the screw of the pump socket
 2. Pull the pump 1-2mm out of the socket
 3. Fasten the screw for the pump socket

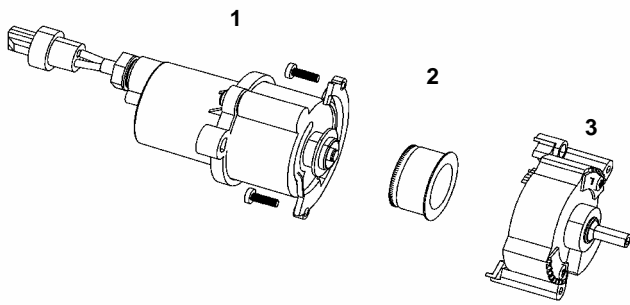

Teil Art.Nr. Bezeichnung

100320 Düse für MANKAR

1	102417	Motor-Modul for atomizer MANKAR
2	100478	Atomiser disc for segment atomiser
3	101996	Segment-module for atomiser incl. Width adjustments

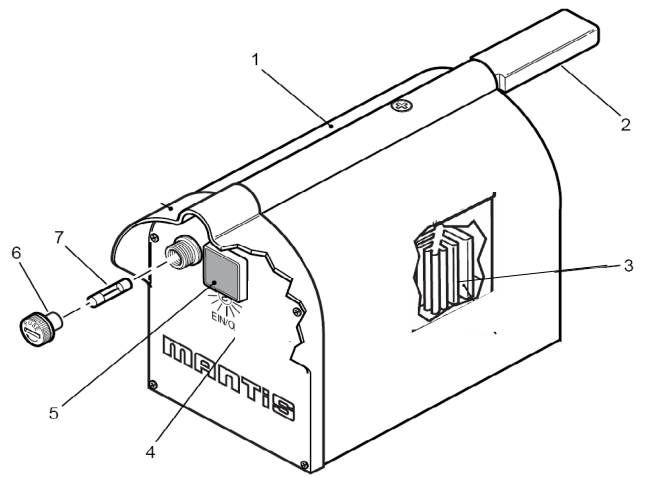

Teil Art.Nr. Bezeichnung

100459 Powerpack mit 1 Akku 6 V - 7 Ah für MANKAR-P,-110P

1	100469	Powerpack housing
2	100461	Powerpack mounting bar for MANKAR
3	100667	Converter 12V to 6V
4-7	101565	Powerpack-cover MANKAR, complete assembled
4	100466	Powerpack cover
5	100464	Switch with control light
6	100365	Fuse holder complete
7	100730	Fuse T3.15 Amp

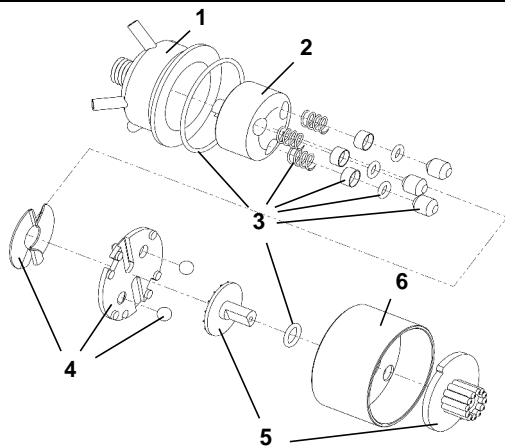

Teil Art.Nr. Bezeichnung

100522 Dosierpumpe MANKAR-3, Kapazität 5 - 10 ml/min

1	100528	Pump housing, 2 pressure lines,
2	102209	Rotor-3, chromed brass for piston pump
3	102373	Sealing kit for MANKAR/MAFEX-3
4	101626	Repair kit, MANKAR, pressure plate/wobble plate
5	102429	Repair kit, MANKAR, selector/adustment knob
6	100534	Pump cover

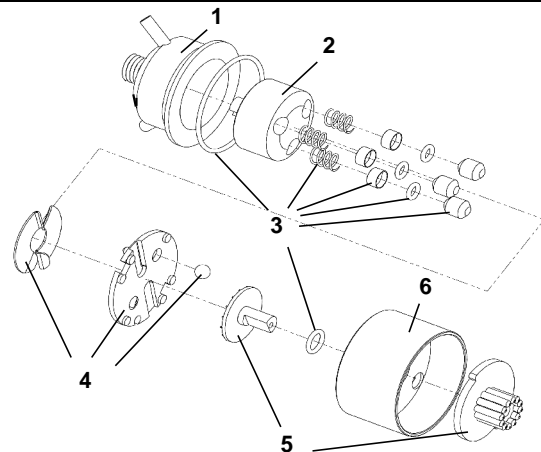

Teil Art.Nr. Bezeichnung

100492 Dosierpumpe MAFEX-3, Kapazität 2 - 20 ml/min

1	100493	Pump housing, 1 pressure line
2	102209	Rotor-3, chromed brass for piston pump
3	102373	Sealing kit for MANKAR/MAFEX-3
4	102436	Repair kit, MAFEX, pressure plate/wobble plate
5	102437	Repair kit, MAFEX, selector/adustment knob
6	100534	Pump cover

Fault remedy

Fault	Cause	Remedy
Atomiser disc not Turning	Atomiser contaminated	Thoroughly clean atomiser, remove plant parts if needed
	Fuse blown	Replace fuse on powerpack (Replacement fuses are located in the powerpack housing)
	No electrical contact	Check cable or connector contact
	Battery defective	Install new battery
	Atomiser motor defective	Install new motor
		Connect the brown cable to Plus (+).
Atomiser spray one-sided	Rotation disc turning in the wrong direction	Connect cable correctly! Selectively plug the brown cable onto the contact pin on the switch/valve unit Connect the blue cable via the round pin plug. Check to ensure the battery connection to the powerpack is correctly poled, blue cable to Plus (+).
Atomiser spray too wide	Width adjustment improperly set	Loosen the screw F (see page 4) and correct the width setting to the left or to the right, respectively
Atomiser drips	Pump incorrectly set	Check setting, see table
	Atomiser disc defective / contaminated	Replace / clean disc
	Atomiser spray discharge contaminated	Clean
Atomiser foams	Residual water in system	Completely empty container, hose, segmental atomiser.
Chemical not flowing evenly	Filter contaminated	Unscrew filter, clean screen.
Air in hose line	Hose connection / Filter leaking	Slightly shorten the hose and set onto a hose nipple. Re-tighten the screw on the filter.

GUARANTEE

- I. If the purchase is a commercial transaction for both sides, the Customer must examine the goods immediately on receipt, as far as this is possible during the regular course of business and if there is a defect, inform the Vendor immediately.
- II. If the Customer does not make a complaint, the goods are considered approved, unless there is a defect, which was not visible during the examination. Furthermore §§ 377 ff. HGB applies.
- III. The Vendor may choose to eliminate the defects or deliver an item free of defects, (rectification of defects). If the rectification of defects fails, the Customer has the right to choose to either demand a reduction in price or to withdraw from the contract.
- IV. Further claims from the Customer, in particular due to consequential damage caused by a defect are in principle disqualified. This does not apply in cases of intent, gross negligence or breaches of contract by the Vendor as well as in cases of injury to life, body or health. The right of the Customer to withdraw from the contract remains unaffected.
- V. Warranty claims lapse after 24 months, respectively after 12 months in case of commercial use of the goods. The limitation period begins at delivery. The guarantee expires, if the delivered goods change or are handled incorrectly.
- VI. The Vendor is not responsible for material defects on deliveries, which he sources from third parties and forwards unchanged to the Customer. Responsibility in the case of intent or negligence remains unaffected. The preceding regulations do not imply a change to the burden of proof to the disadvantage of the Customer.
- VII. Claims for defects do not only exist in cases of negligible deviations from the agreed properties and conditions or only in negligible impairment of usefulness.
- VIII. Necessary expenses for the purpose of the rectifying defects are to be paid by the Customer, if they increase due to delivery to a different place than the place of business of the Customer, unless the transport corresponds to its intended use.

EG-Declaration of conformity Council Directive 2006/42/EG

Mantis ULV-Sprühgeräte GmbH, Vierlander Straße 11 a, 21502 Geesthacht declares under our sole responsibility that the following products are in conformity with the provisions of the following Council Directive: 2006/42/EG

Typ	MANKAR-ONE, MANKAR-TWO
Typ	MANTRA, MINI-MANTRA / PLUS, MICRO-MANTRA, MICRO-VASO, MANKAR HQ
Typ	FLEXOMANT-1W, FLEXOMANT-2W, FLEXOMANT-3W, FLEXOMANT-4W, FLEXOMANT-PLUS, VARIMANT-1, VARIMANT-2, VARIMANT-4 PLUS, VARIMANT-WINNER-TOP, VARIMANT-WINNER-UNO
Typ	MAFEX
Typ	ROFA

Hiske Weissmann
Managing Director



(Name, title and signature)

Geesthacht January 2015

(Place and date of signature)